

N7018A Type-C Test Controller

Full control of the USB Type-C interface for high speed compliance testing

- Stand-alone GUI to USB connection for manual operation
- Set power contracts up to 100 Watts for provider and consumers of power
- Set alt mode to Thunderbolt, DisplayPort 2+2, or DisplayPort 4 lane modes
- Power supply interface to Keysight N6701C for supply and load with one connection
- USB3.1 Low Frequency Periodic Signaling source
- Thunderbolt and DisplayPort automation interfaces
- Probe access for SBU1/SBU2, CC1/CC2 and VBUS
- Front panel indicators of VBUS range and CC line selection



Figure 1. N7018A with N7015A Type-C fixture connection to lap top controlled by graphical user interface (shown on oscilloscope).

Table of Contents

Designed for Debug, Compliance and Full Design Validation.....	3
Debug Features	5
Graphical User Interface	5
Setup Tab	6
Power Tab.....	7
LFPS Tab.....	8
Signal Access and Control.....	9
Automation with the N7018A.....	11
Keysight Type-C compliance software.....	11
Power Supply and PDO contracts in the Test Plan.....	12
Ordering Information	13
Other USB Type-C™ Accessories	13
Other Recommended Probes and Accessories	13
Related Literature	14

Designed for Debug, Compliance and Full Design Validation

The N7018A Type-C Test Controller supports the turn-on and debug needs, compliance verification, and full automated qualification testing of products with the USB Type-C connector for the USB3.1, Thunderbolt3, and DisplayPort standards. It is an indispensable Type-C system element as it supports full range of connection, operational mode, and power delivery states of any Type-C device. It further enables automation in any of the standards by routing the SBU lines of the type c interface to industry standard controllers for the alt modes (DisplayPort and Thunderbolt) and by furnishing Low Frequency Periodic Signaling for USB3.1 device control.

Small size: Big footprint.

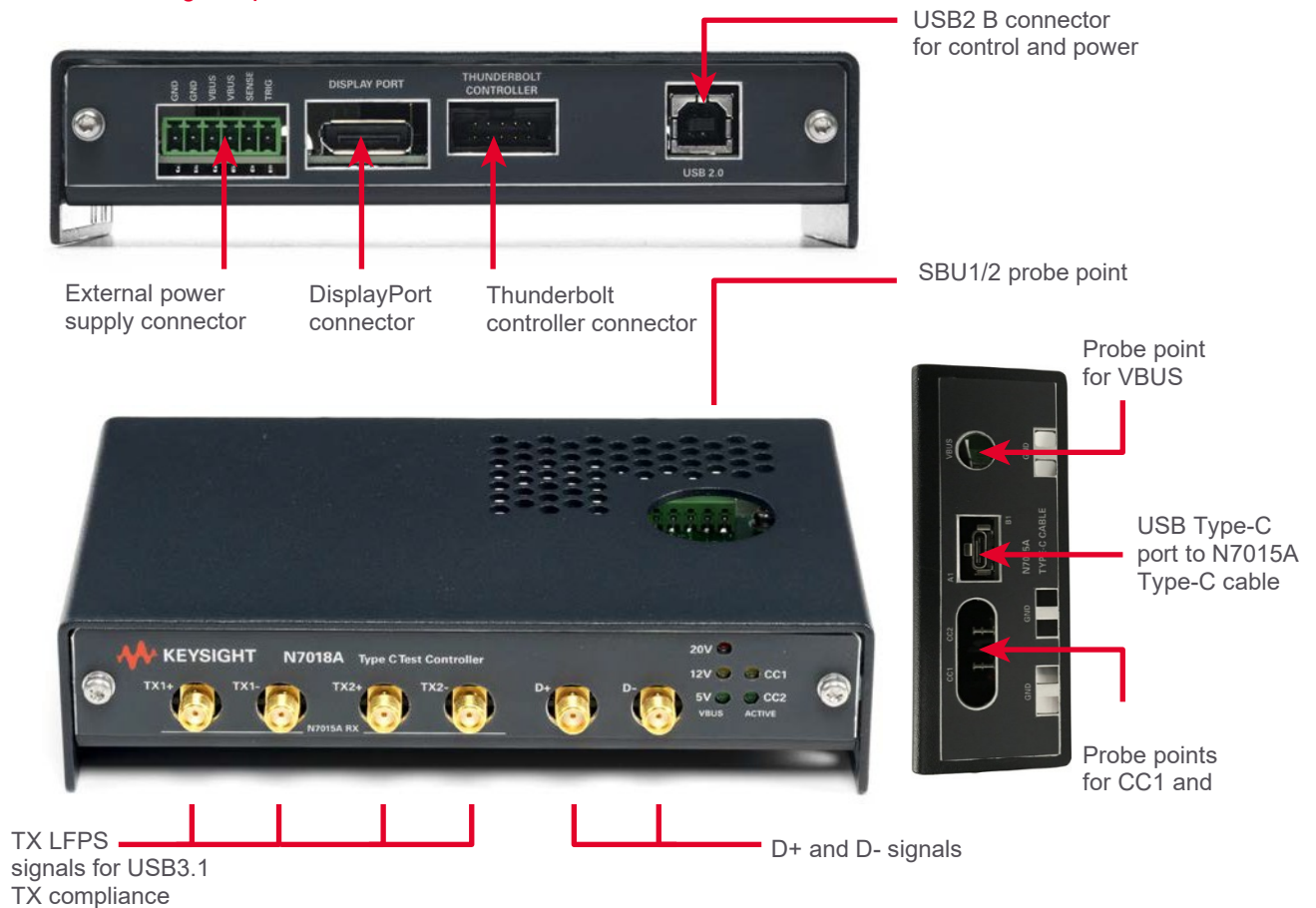

Figure 2. N7018A Type-C low-speed fixture

A simplified block diagram of the N7018A and its connections is shown below.

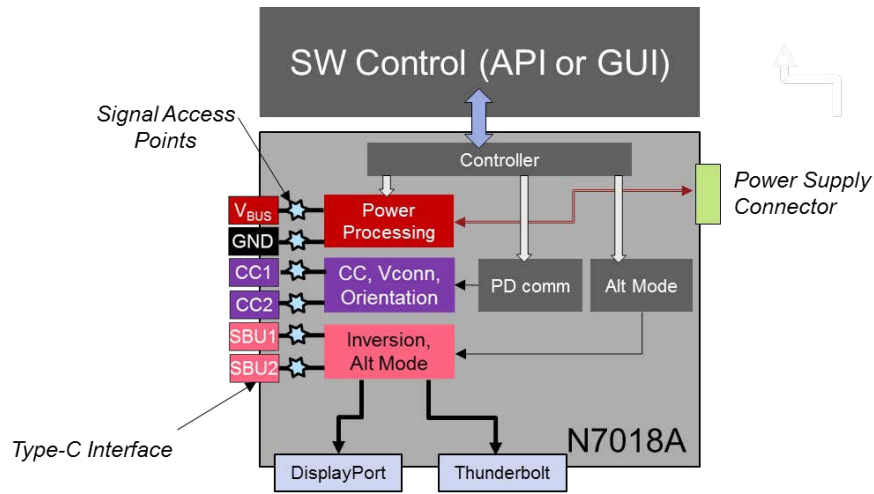

Figure 3. Simplified N7018A block diagram

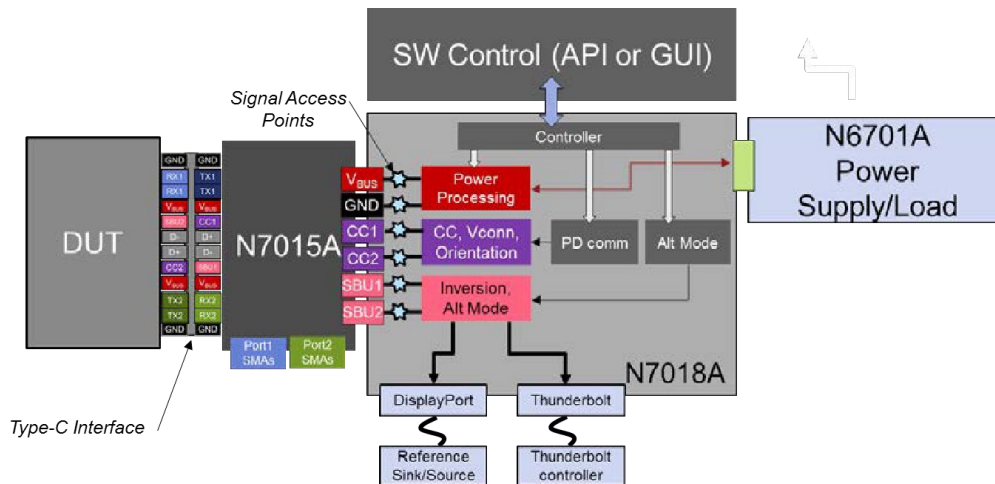

Figure 4. N7018A connected in a system

Debug Features

The N7018A Type-C test controller can be operated remotely, as is the case when under compliance application control or it can be controlled 'manually' by virtue of a graphical user interface. Using the N7018A control GUI simplifies the task of integrating a test system by confirming the control and operation of the device under test with the controller and enables focus on specific functions in a product bring up.

Graphical User Interface

The N7018A Type-C low-speed test fixture requires the installation of a software controller graphical user interface to operate. The controller software offered with the N7018A can be installed on a PC or on the Infiniium oscilloscope itself for convenience. The controller software is downloadable from <http://www.keysight.com/main/software.jsp?ckey=2674876&lc=eng&cc=US&nid=-33524.1140138&id=2674876>.

There are three tabs in the GUI. For all three tabs, the screen presents status indication of the connection from the host controller (pc or lap top) to the N7018A through the USB2 interface. This indicator will be a green 'connected' if it is under normal operation and might be a yellow 'disconnected' before you click on 'Connect to the Controller' button. There are also indicators on the bottom of the screen that will indicate the status of delivery contract as well as mode of operation (i.e. alt mode such as Thunderbolt). Other indicators on the bottom are the data role, active port of the interface, type of PD contract in place, and values of the VBUS of the Type-C connector and the power supply connector. At a glance, you can know a lot about the current state of the system.

Setup Tab

The setup tab provides the setting of the three key parameters in a connection and contract. These are the orientation (i.e. the active port), the power role of the Type-C Test Controller and the operational mode (transmitting standard). To begin (say when testing a host, or DFP, device) the user should set the power role of the Type-C Test Controller to the Consumer mode. In this way, a basic contract is made and the controller will be demanding only a small amount of current from the device or controlling device. Selecting Normal or Flipped for connector orientation determines the active port for USB3 testing and in general, the orientation of the interface for testing purposes. For USB3.1, only one TX port will be active at a time so the orientation selection must be correct to see a specific TX pair (TX1+, TX1- or TX2+, TX2-) on a scope channel. To establish a connection with the DUT, press the 'Establish Connection' button. 'Break connection' is best used to disconnect completely from the DUT and make sure the VBUS is at Vsafe (0 volts) before removing the N7015A test fixture. The 'Establish Connection' process includes a 'Break Connection' implicitly, so it is unnecessary to hit both buttons sequentially. An operating mode must always be selected. For DisplayPort two choices are possible and these are standard 4 lane operation and 2 lane operation with the other two lanes of the Type C interface being dedicated to USB3.1 (called 'DisplayPort 2+2').

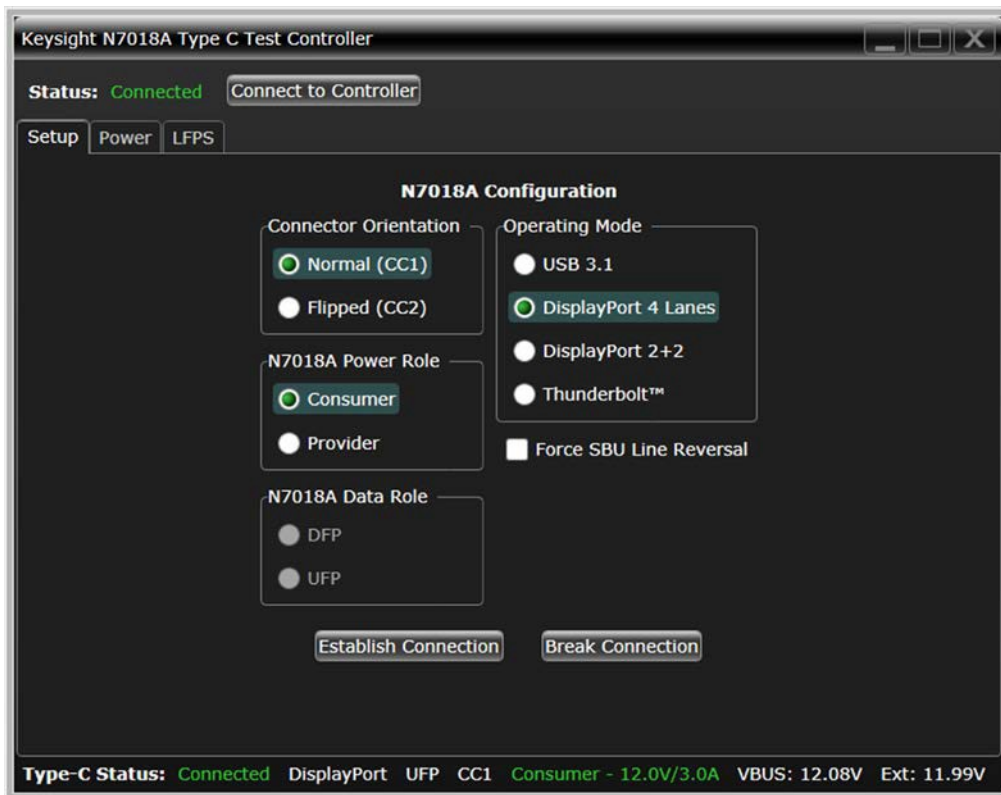

Figure 5. Setup tab of the N7018A. Note the status indicators on top and bottom

Power Tab

Upon entering the power tab, a basic contract or another previously established contract will be in place and shown at the bottom of the screen in the 'Active Provider PDO' and 'Active Consumer PDO' areas. The N7018A can be either the provider or the consumer depending on the selection in the 'Setup' tab. Depending on the initial contract, the GUI will present the available PDOs for the power role selected. If the basic consumer contact is in place, those PDOs will be Provider PDOs. You have access to all the device under test's PDOs when you select 'Refresh list' — You can then click on the PDO desired and click on 'Select Target PDO'. If an external power supply is connected to the N7018A, then the N7018A can be selected as the Provider in the Setup tab. The power supply must be set to 5V/3A to setup the initial contract with 'Establish Connection'. In the power tab, you can then read the 'Available Consumer PDOs' and select the one that you want to provide to the DUT. You can set the maximum current you want the supply to provide. (NOTE: Some DUTs will use higher current that the Consumer PDO states, so it is best to set this to 3A). Finally, if the target PDO has a variable voltage, enter a value between the Min and Max voltages that the consumer PDO desires. The rest of the operation is similar to the N7018A as a Consumer operation. To finish, click on 'Setup New Contract'. Examine the GUI status indications for expected response. The 'Active Consumer PDO will update to show the contract the DUT is using.

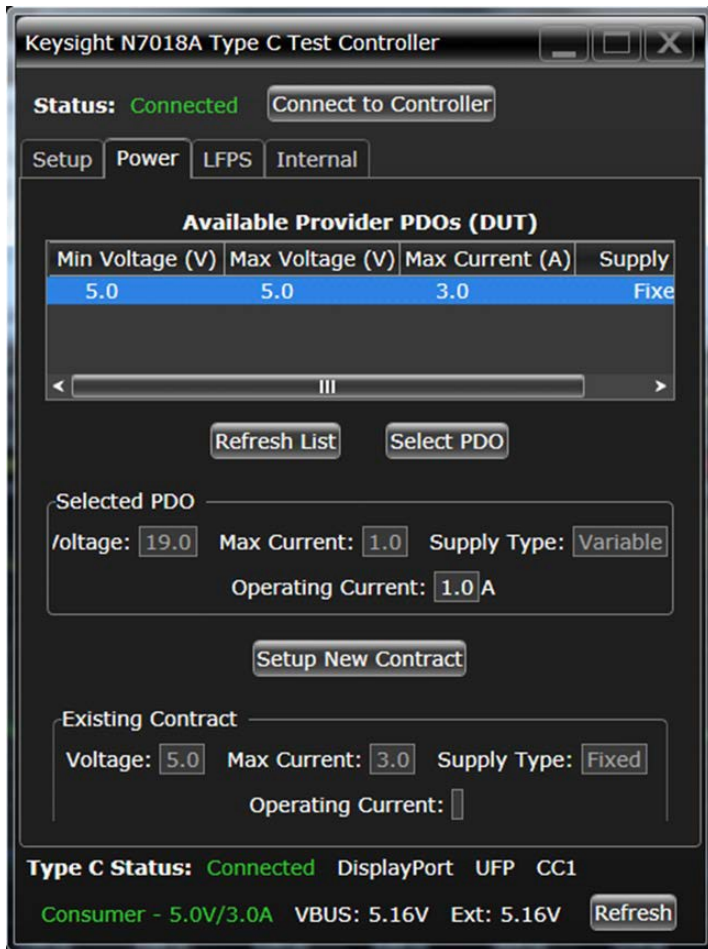

Figure 6. Power Tab on the N7018A Type-C Test Controller

LFPS Tab

The LFPS tab is specifically for the generation of LFPS (Low Frequency Periodic Signaling) signals for testing USB3.1 devices. There are ping signals and LBPM (LFPS based Pulse width modulation Messaging) that are used.

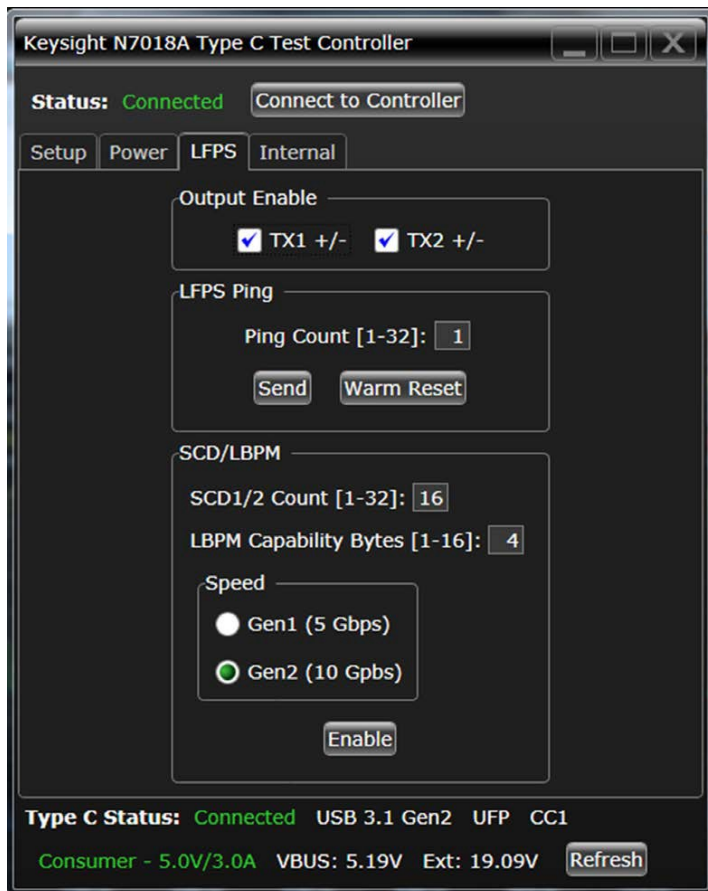

Figure 7. LFPS Tab of the N7018A

Signal Access and Control

CC line Control: A very basic feature of the Type C interface is its orientation independence which is a feature that in systems relies on a single wire in the cable to be connected to a link partner. The single wire, though key in the technology, prevents convenient control to test both ports (Port 1 and Port 2). The Keysight N7015A Type-C cable has two wires for the cc lines so control of the active port is had by the N7018A by termination control (value of termination resistance on either cc line). The N7018A can therefore, electronically 'flip' the interface as if it was the cable that was inverted, to verify signals on either port. In this manner, various behaviors of device under test can be validated such as recognition of product whether Upstream Facing or Downstream Facing, as well as port control simulating cable connections. The cc lines are exposed for measurement purposes such as for Power Delivery compliance testing or for power delivery channel protocol packet and packet exchange analysis.



Figure 8. The CC1 and CC2 can be conveniently probed using a Keysight passive probe

SBU signal access: the sideband utility lines are not used in USB3.1, however, have very important roles in DisplayPort and Thunderbolt. The SBU probe 'point' is actually 3 probe points. Shown below is picture of the configuration and also a mechanical portrayal of the pins that can be probed. The probe access point is configured as 4 pins in a 2x2 arrangement. A differential probe (E2678B) is connected across pins A1 and B1 rendering a differential connection which would be useful in the evaluation of the AUX channel in Displayport. Single ended connections can be accomplished by changing the probe connection to A1 to A2 or B1 to B2. In this case, two such probes could be used to probe the single ended signals which might be useful in analyzing the single ended signals of Thunderbolt on the Low frequency Rx and TX lines.

Data signals: The USB2 data signals are routed to the power delivery chip for billboarding. USB2 testing is best accomplished with other fixtures for test access.

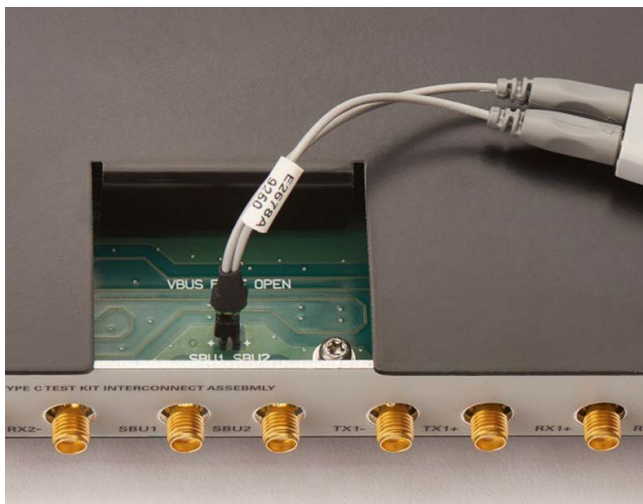

Figure 9. Use the E2678B socketed head with InfiniiMax I/II probe amp to probe SBU signals

V_{Bus}: Power delivery is manifest through the VBus pins on the type C interface. It can be probed directly through the window in N7018A. It is possible to analyze the coarse DC voltage, voltage rail noise, and the voltage trajectory between one state and another.



Figure 10. VBus probing on N7018A

Automation with the N7018A

The N7018A Type-C Test controller is integrated into the Keysight compliance applications for the standards that use the USB Type-C connector. These compliance packages are tabulated below.

Keysight Type-C compliance software

Standard	Transmitter compliance sw	Receiver compliance sw
USB3.1	U7243C	N5990A option 102 with option 006 (Type-C)
DisplayPort over Type-C	U7232E	N5990A option 155 with option 006 (Type-C)
Thunderbolt3	N6470B	N5990A option 120 with option 006 (Type-C)

For each application, the user activates the Type C environment in the setup and the software finds the N7018A Type-C Test Controller and proceeds to guide the user in the Type-C setup. An example is shown below:

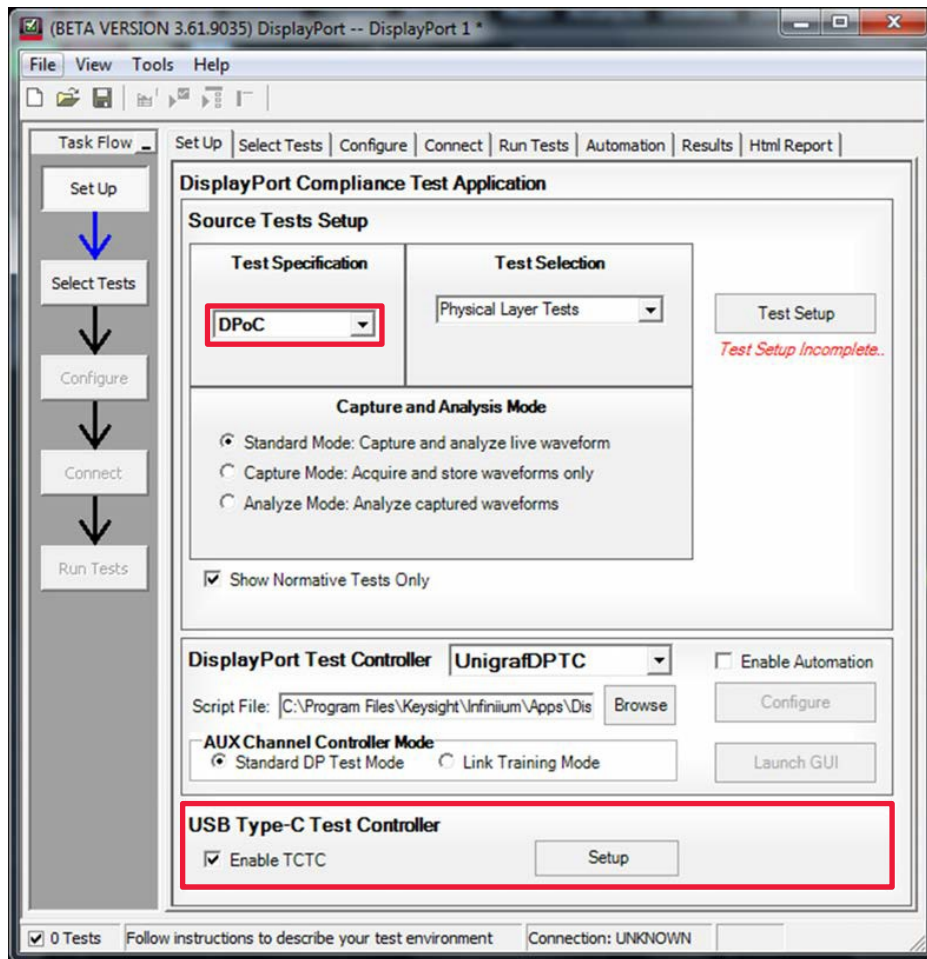

Figure 12. Type C environment setup enabling N7018A on Keysight U7232E DisplayPort compliance software

Power Supply and PDO contracts in the Test Plan

Whether under automation, or operating the N7018A with the controller GUI, the user has a selection in how the power supply is implemented in his system. If, for instance, the device to be tested is always a consumer at 12 volts, a 12 volt fixed supply may be chosen—in the compliance applications the user would select 'FIXED Supply'. With this selection, however, full automation where different power contracts can be made and included in the test plan cannot be achieved. To accomplish full automation, Keysight recommends the N6700 power supply family of products to be selected. These, with the N6786A module, can source and sink current and the PDO can be included as a test parameter in the test plan; for instance, you can run jitter tests on a product using different PDOs and the report will identify the different PDOs used in the results. In this way, you can explore performance variation versus PDO contract.



Figure 13. Use an external power supply to supply (N6701C with N6786A module shown here)

Environmental and safety characteristics

	Description
Temperature	Operating: 0 to +55 °C
	Non-operating: -40 to +70 °C
Humidity	Operating: Up to 95% RH at or below +40 °C; up to 80% RH up to +65 °C
	Non-operating: Up to 90% RH up to 65 °C
Altitude	Operating: Up to 4,600 m (15,000 ft)
	Non-operating: 4,600 m
Safety	IEC 61010-1:2010/EN 61010-1:2010 (3rd Edition)

Ordering Information

Model numbers	Description
N7018A	Type-C Test Controller
N6701C	Power Supply chassis
N6786A	5 to 20 volt/80 Watt max Supply/Load Note: 100Watt contracts require two N6786A modules

Other USB Type-C™ Accessories

Model numbers	Description
N7015A	Type-C high-speed test fixture, includes wrench

Other Recommended Probes and Accessories

Model numbers	Description
1130A	InfiniiMax 1130A 1.5 GHz probe amplifier
E2678B	Socketed probe head for InfiniiMax I/II amp
N2871A	200 MHz 10:1 passive probe
N2823A	Cable assembly, coax phase matched pair, 1 m, 2.92 mm (m) to 2.92 mm (m) matched to < 5 ps
N5448B	Cable assembly, coax phase matched pair, 25 cm, 2.92 mm (m) to 2.92 mm (m) matched to < 5 ps
11904B	Test port adapter for connecting 2.4 mm (m) to 2.92 mm (m)
N9398C	DC blocking capacitor
5061-5311	Coax connector saver adapter, 3.5 mm (f) to 3.5 mm (f)
N2787A	3D probe positioner
8710-1765	Torque wrench, 8 lbs, 5/16 inch (for connecting N7015A to the scope input)



Related Literature

Publication title	Publication number
N7015A, N7016A and N7017A Type-C Test Fixtures - Data Sheet	5992-1073EN
1130B-Series Differential and Single-Ended Probes - User's Guide	01130-97012
N6470A Thunderbolt 3 Transmitter Compliance Test Software for Infiniium Oscilloscopes - Data Sheet	5992-1654EN
U7243B USB 3.1 — 5 Gbps and 10 Gbps Transmitter Compliance Software - Data Sheet	5992-0154EN
U7232D DisplayPort Electrical Performance Validation and Compliance Software - Data Sheet	5992-1051EN
N5990A Test Automation Software Platform - Data Sheet	5989-5483EN

 www.axiestandard.org
AdvancedTCA® Extensions for Instrumentation and Test (AXIe) is an open standard that extends the AdvancedTCA for general purpose and semiconductor test. The business that became Keysight was a founding member of the AXIe consortium. ATCA®, AdvancedTCA®, and the ATCA logo are registered US trademarks of the PCI Industrial Computer Manufacturers Group.

 www.lxistandard.org
LAN eXtensions for Instruments puts the power of Ethernet and the Web inside your test systems. The business that became Keysight was a founding member of the LXI consortium.

 www.pxisa.org
PCI eXtensions for Instrumentation (PXI) modular instrumentation delivers a rugged, PC-based high-performance measurement and automation system.



Download your next insight

Keysight software is downloadable expertise. From first simulation through first customer shipment, we deliver the tools your team needs to accelerate from data to information to actionable insight.

- Electronic design automation (EDA) software
- Application software
- Programming environments
- Productivity software

Learn more at

www.keysight.com/find/software

Start with a 30-day free trial.
www.keysight.com/find/free_trials

Learn more at: www.keysight.com

For more information on Keysight Technologies' products, applications or services, please contact your local Keysight office. The complete list is available at: www.keysight.com/find/contactus

